

Roll No.

Total No. of Questions : 09]

[Total No. of Pages : 02

B. TECH. (Sem. - 1st/2nd)
ENGINEERING DRAWING & COMPUTER GRAPHICS
SUBJECT CODE : ME - 102 (2K4 & onwards)
Paper ID : [A0116]

[Note : Please fill subject code and paper ID on OMR]

Time : 03 Hours

Maximum Marks : 60

Instruction to Candidates:

- 1) Section - A is **Compulsory**.
- 2) Attempt any **Five** questions from Section - B & C.
- 3) Select atleast two questions from Section - B & C.

Section - A*(Marks : 2 each)***Q1)**

- a) Draw a symbol of third angle projections.
- b) What are the standard sizes of drawing sheets according to I.S.I and which is suitable for drawing work?
- c) Where and why a cutting plane is drawn in a drawing?
- d) What are the different methods of dimensioning?
- e) What is the Representative Fraction (R.F.) or Scale Factor (S.F.)?
- f) What is the difference between a quadrilateral and a polygon?
- g) Name the principal planes of projections.
- h) What is a sectional view? Why sectional views are used in drawing?
- i) What do you understand by V.T. and H.T. of section plane?
- j) Give the practical applications of the intersection of surfaces or interpenetration of solids.

Section - B*(Marks : 8 each)*

Q2) Construct a diagonal scale of R.F. = 1/5000 to show hundred meters, ten meters and single meter and long enough to measure upto 500 meters. Also show the distance 467 meters on it.

Q3) A straight line AB 60 mm long makes an angle of 45° to HP and 30° to the VP. The end A is 15 mm in front of VP and 25 mm above HP. Draw the projections of the line AB.

J-751/8129/

P.T.O.

- Q4)** A right regular pentagonal pyramid, edge of base 25 mm and height 55 mm is held on ground plane on one of its base corners, such that its axis is inclined at 30° to ground plane and 45° to VP. Draw its projections.
- Q5)** A cylinder of 45 mm diameter and 60 mm long is resting on one of its bases on HP. It is cut by a section plane inclined at 60° with HP and perpendicular to VP passing through a point on the axis 15 mm from its top end. Draw its sectional top view, front view and sectional end view.

Section - C

(Marks : 8 each)

- Q6)** A right regular square prism, side of base 25 mm and height 50 mm, rests on its base on HP such that its vertical faces are equally inclined to the VP. A horizontal circular hole of diameter 30 mm drilled centrally through it such that the axis of the hole cuts the diagonally opposite vertical edges. Develop its lateral surface.
- Q7)** A right circular cone, diameter of base 50 mm and height 60 mm, resting on its base in HP, is completely penetrated by a cylinder of diameter 25 mm and 70 mm long. The axis of the penetrating cylinder is parallel to both HP and VP and intersects the axis of the cone at a distance of 20 mm from its base. Draw the projection of the solids showing curve of intersection.
- Q8)** A cylindrical slab 60 mm diameter and 20 mm thick is surmounted by a cube of 28 mm edge. On the top of a cube, rests a square pyramid, attitude 30 mm and side of base 15 mm. The axes of the two solids are in same straight line. Draw isometric projections of the solids.
- Q9)** Draw the following view of given figure
(i) Front view (ii) Top view (iii) Left side view.

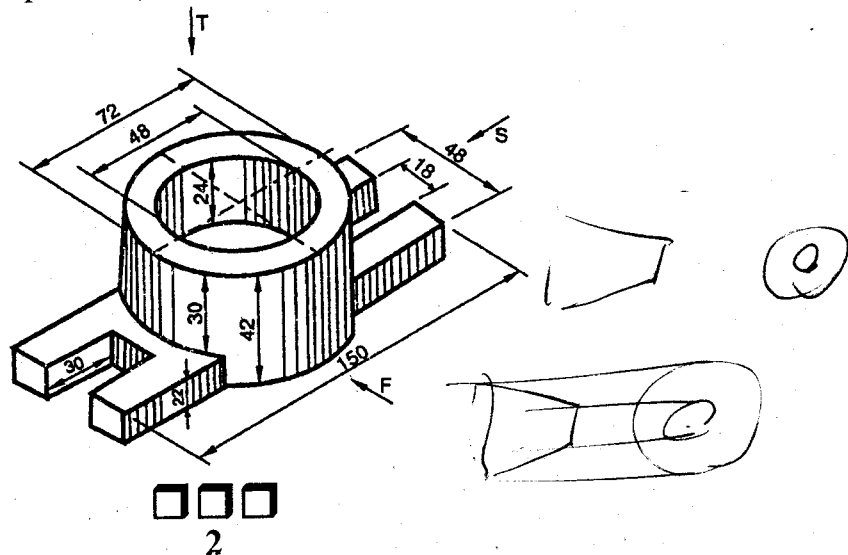

J-751